

中空卡盘
中空油缸
后拉夹盘
中实卡盘
中实油缸
气动卡盘
超薄夹头
手动卡盘
轮毂夹盘
卡盘配件
生爪硬爪
连接盘
拉料器
刀座
刀套
延长杆
顶尖
虎钳
分度盘
磨床工具
磁盘
万力
线割
表架
工具

车床卡盘

铣床虎钳

磨床磁盘

线割配件

机械工具

5110 双向冲子成型器 PUNCH FORMER PFA

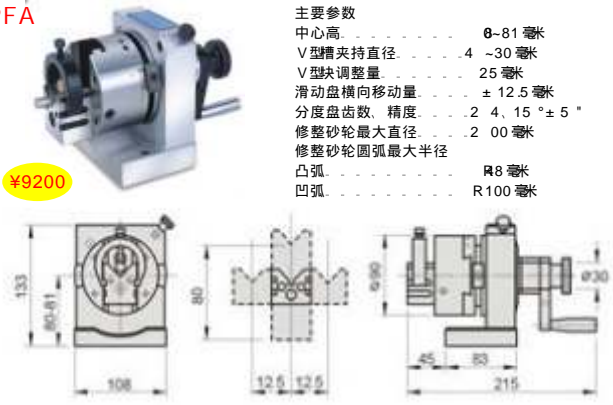

主要参数
中心高 8-81 毫米
V型精夹持直径 4-30 毫米
V型块调整量 25 毫米
滑动盘横向移动量 ±12.5 毫米
分度盘齿数、精度 24、15°±5'
修整砂轮最大直径 200 毫米
修整砂轮圆弧最大半径
凸弧 R8 毫米
凹弧 R100 毫米

5115 单向冲子成型器 PUNCH FORMER PFB

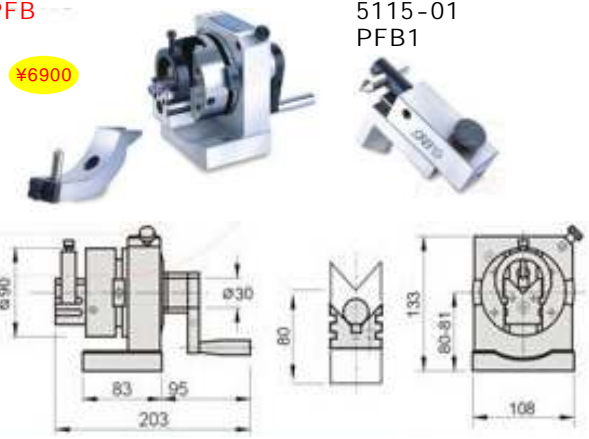

5115-01
PFB1

5120 三爪冲子成型器 3-JAWS PUNCH FORMER PFC

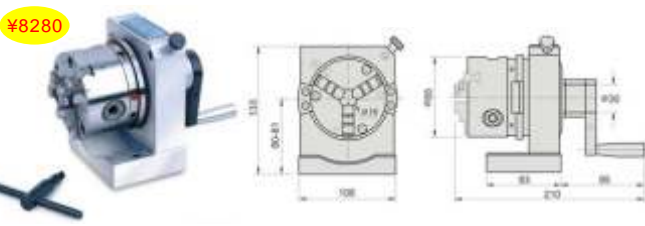

5125 筒夹式ER冲子成型器 ER COLLET PUNCH FORMER PFD

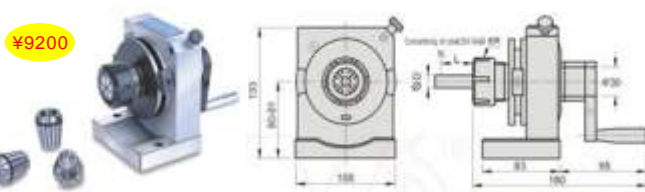

Order NO.	Model	Collet Size	Price
5125-16	PFD	1, 2, 3, 4, 6, 8	7765
5125-32		4, 6, 8, 10, 12, 16, 20	7765
5125-40		6, 8, 10, 12, 16, 20, 25	8595

5145 冲子研磨机 PUNCH GRINDER PGA

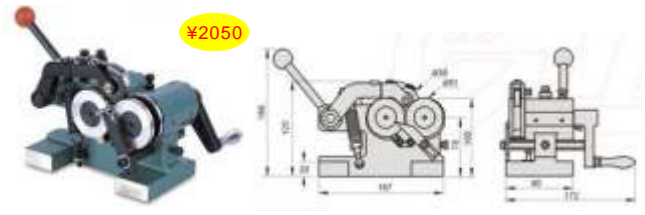

5150 冲子研磨机 PUNCH GRINDER PGAS

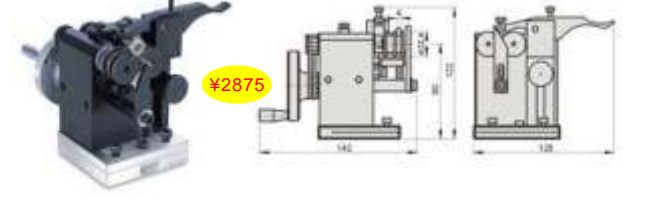

5155 电动冲子研磨机 MOTOR PUNCH GRINDER PGAM

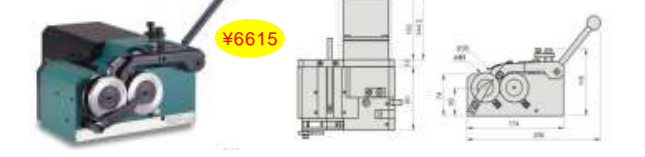

Order NO.	Model	Volts
5125-16	PFD	1, 2, 3, 4, 6, 8
5125-32		4, 6, 8, 10, 12, 16, 20
5125-40		6, 8, 10, 12, 16, 20, 25

5210 万能砂轮修整器 UNIVERSAL WHEEL DRESSER WDI65

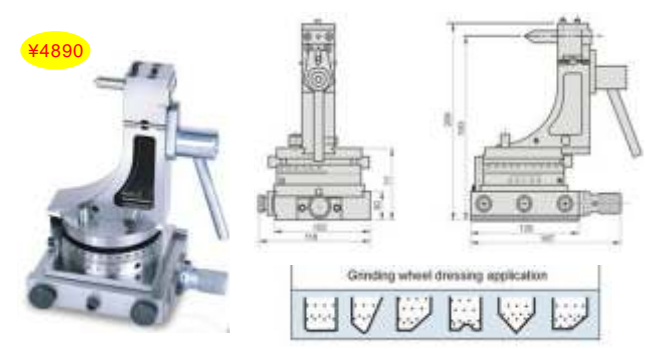

5230 透视万能砂轮修理器 VISUAL RADIUS ANGLE DRESSER KT50

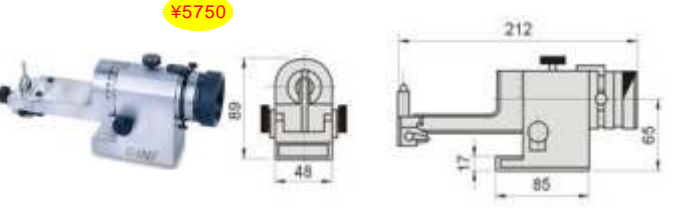

5235

精密砂轮厚度修理器 PRECISION DUPLEX DRESSER

DF60

¥2300

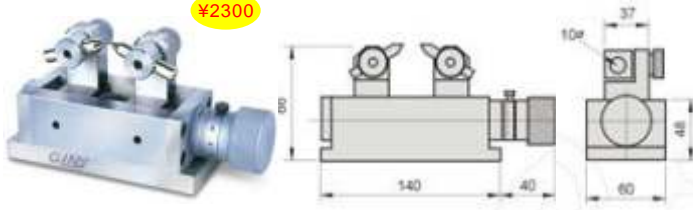

5240

砂轮角度成型器 ANGLE SINE DRESSER

AP50

¥1130

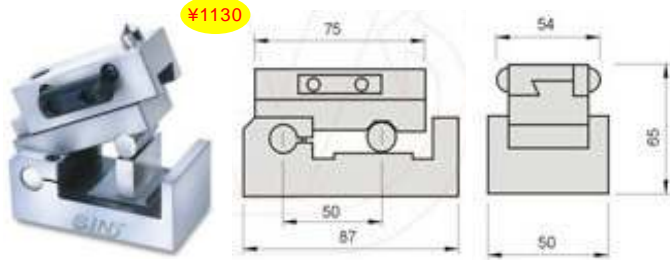

5250

钻石砂轮修正器 DIAMOND CBN FLAT WHEEL TRUER

DT100

¥2300

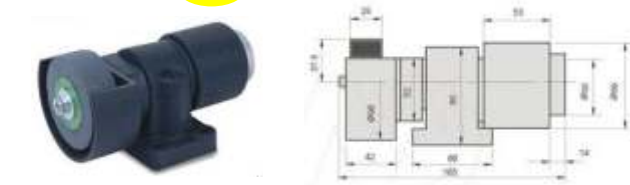

5255

电动钻石砂轮修正器
MOTORISED DIAMOND CBN FLAT
WHEEL TRUER

DTM100



Order NO.	Model	Volts	Price
5255-110	DTM100	110V 1Phase	3740
5255-220	DTM100	220V 1Phase	3740

5310

磨床用砂轮法兰 FLANGE

F250

F250 适用于建德磨床主轴使用

¥145

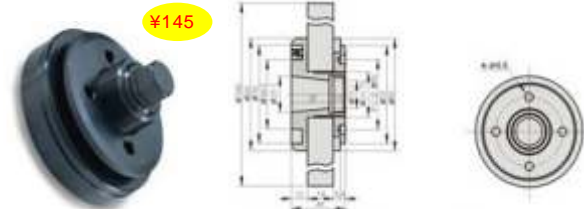

5312

磨床用砂轮法兰 FLANGE

F350

F350 适用于大同磨床系列机床主轴使用

¥145

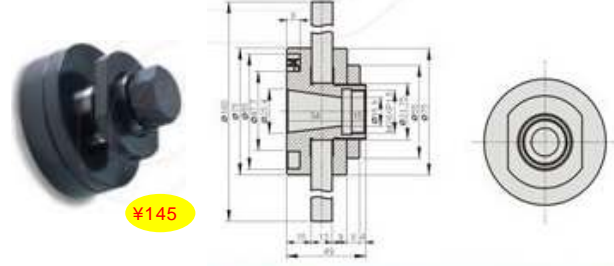

5410

磁性正弦规 MAGNETIC SINE BAR

SB50

¥1200



精度 材质
平行度：0.002mm以内
直角度：0.005mm以内
双轴精度：+0.002
材质：YK-30
硬度：HRC56° ±68°

5415

正弦规 SINE BAR

S100

¥480



5420

可调式角度垫规磁性正弦规
ADJUSTABLE ANGLE PLATES

AP25\30\46

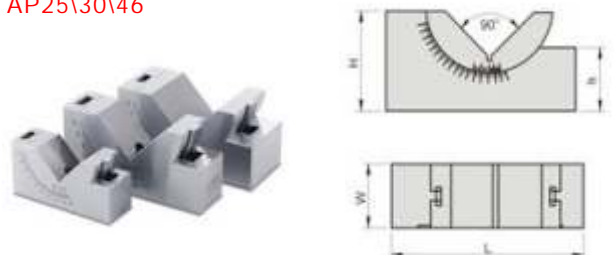

Unit:mm

Order No.	Model	L	W	H	h	N.W.(Kg)	Price
5420-25	AP25	75	25	36	25	0.5	780
5420-30	AP30	102	30	49	30	1.0	900
5420-46	AP46	102	46	49	30	1.5	1020

中空
卡盘
中空
油缸
后拉
夹盘
中实
卡盘
中实
油缸
气动
卡盘
超薄
夹头
手动
卡盘
轮毂
夹盘
卡盘
配件
生爪
硬爪
连接盘
拉料器
刀座
刀套
延长杆
顶尖
虎钳
分度盘
磨床
工具
磁盘
磁力
线割
表架
工具

车床
卡盘

铣床
虎钳

磨床
磁盘

线割
配件

机械
工具

中空卡盘
中空油缸
后拉夹盘
中实卡盘
中实油缸
气动卡盘
超薄夹头
手动卡盘
轮毂夹盘
卡盘配件
生爪硬爪
连接盘
拉料器
刀座
刀套
延长杆
顶尖
虎钳
分度盘
磨床工具
磁盘
万力
线割
表架
工具

车床卡盘

铣床虎钳

磨床磁盘

线割配件

机械工具

5425

B型精密V型台 VEE BLOCKS

A2-6



Order No.	Model	A	B	C	E	F	G	N.W.	Price
5425-02	A2	50	19	24	24	17	13	0.26kg	420
5425-03	A3	75	24	35	37	24	16	0.8kg	540
5425-04	A4	100	33	52	50	30	20	2.5kg	780
5425-05	A5	125	44	69	63	37	26	5kg	1255
5425-06	A6	150	50	80	75	45	30	7.8kg	1855

5430

附夹V型台 A PAIR OF V BLOCKS
夹持范围: 2-∅

PV100

¥940

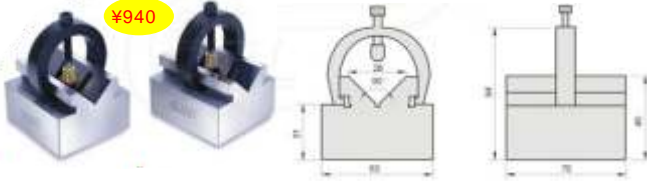

5440

精密双刀口直角尺 HARDENED STEEL SQUARES

H304、306、308、310、312

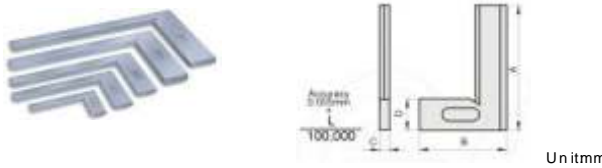

Order No.	Model	A	B	C	D	N.W.	Price
5440-04	H304	100	70	5	22	0.2kg	325
5440-06	H306	150	100	7	30	0.4kg	440
5440-08	H308	200	130	8	33	0.6kg	525
5440-10	H310	250	165	10	38	1.3kg	735
5440-12	H312	300	200	10	40	1.6kg	855

5455

精密虎钳平行垫规 PRECISION PARALLELS SET

P85



¥820

Model	W x H x L x ES
P85	8.5 x 4 x 50 x 2
	8.5 x 6 x 50 x 2
	8.5 x 8 x 50 x 2
	8.5 x 10 x 50 x 2
	8.5 x 12 x 50 x 2
	8.5 x 14 x 50 x 2
	8.5 x 16 x 50 x 2
	8.5 x 18 x 50 x 2
	8.5 x 20 x 50 x 2

5460

精密虎钳平行垫规 PRECISION PARALLELS SET

P100

¥1170

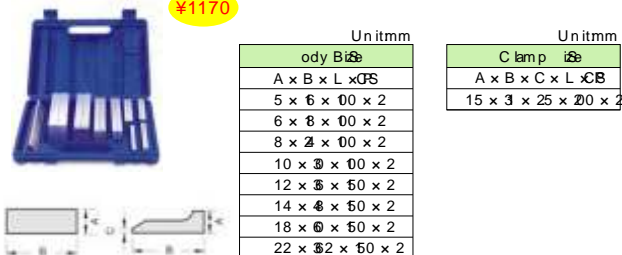

Body Blocks		Clamp Blocks	
A x B x L x CS	Unit:mm	A x B x C x L x CS	Unit:mm
5 x 6 x 100 x 2		15 x 3 x 25 x 20 x 2	
6 x 8 x 100 x 2			
8 x 10 x 100 x 2			
10 x 12 x 100 x 2			
12 x 14 x 100 x 2			
14 x 16 x 100 x 2			
18 x 18 x 100 x 2			
22 x 22 x 100 x 2			

5462

精密虎钳平行垫规 PRECISION PARALLELS SET

P150

¥1400



Unit:mm		Unit:mm	
W x H x L x ES		W x H x L x ES	
10 x 4 x 50 x 2		10 x 2 x 50 x 2	
10 x 6 x 50 x 2		10 x 3 x 50 x 2	
10 x 8 x 50 x 2		10 x 3 x 50 x 2	
10 x 10 x 50 x 2		10 x 3 x 50 x 2	
10 x 12 x 50 x 2		10 x 4 x 50 x 2	
10 x 14 x 50 x 2		10 x 4 x 50 x 2	
10 x 16 x 50 x 2		10 x 4 x 50 x 2	

5465

导磁块 MAGNETIC INDUCTION BLOCK

GT1

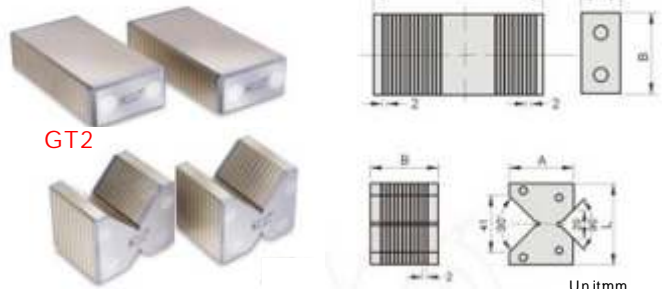

Order No.	Model	A x B x L x CS	N.W.	Price
5465-10	GT1	25 x 50 x 100-2PCS	2.2kg	680
5465-20	GT2	46 x 40 x 80-2PCS	2kg	765

5470

磁性V型台 MAGNETIC V-BLOCK

GVH2 GVH1



Order No.	Model	Holding Power		Dimension			N.W.	Price
		Round	Surface	B	H	Length		
5470-10	GVH1	55kgf	70kgf	56	72	80	2kg	2015
5470-20	GVH2	90kgf	110kgf	76	100	115	5.5kg	3165

5475

磁性V型台 MAGNETIC V-BLOCK

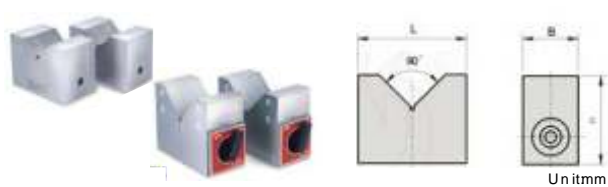

Order No.	Model	Holding Power	Applicable Diameter	Dimension			N.W.	Price
				B	L	H		
5475-30	GVH30	15kgf	50	40	70	50	2kg	3400
5475-40	GVH40	20kgf	80	50	100	80	5kg	6355

5480

方型磁性测定台 MAGNETIC SQUARE & V-BLOCK

BA1、BA2



Order No.	Model	Dimension							N.W.	Price	
		B	L1	H	L2	P1	P2	P3			
5480-10	BA1	100 ± 0.05	100 ± 0.05	100 ± 0.05	43	17	4	12	26 ± 0.05	6.5kg	4040
5480-20	BA2	150 ± 0.12	150 ± 0.12	150 ± 0.12	56	24.5	5	19	32 ± 0.08	22kg	7555

5482-01

脱磁器 HANDY TYPE DEMAGNETIZER

HD123



Unit:mm

Order No.	Model	POWER SOURCE	CAPACITY	DUTY CYCLE	L	W	H	N.W.	Price
5482-01-110	HD123	AC 110V	110VA	90%	128	83	83	1.8kg	1095
5482-01-220	HD123	AC 220V	110VA	90%	128	83	83	1.8kg	1095

5482-02

平面脱磁器 STANDARD TYPE DEMAGNETIZER

HD200



Unit:mm

Order No.	Model	POWER SOURCE	CAPACITY	DUTY CYCLE	L	W	H	N.W.	Price
5482-02-110	HD200	AC 110V	330VA	100%	150	200	100	7.5kg	2285
5482-02-220	HD200	AC 220V	330VA	100%	150	200	100	7.5kg	2285

5487

高速钢块规

STEEL METRIC GAUGE BLOCKS



Unit:mm

Order No.	Model	Total blocks	Class	Nominal dimension(mm)	Steps (mm)	No. of blocks	N.W.	Price
5487-87-0	GB87B ₀	87	0	1.001-1.009	0.001	9	2.9	3580
5487-87-1	GB87B ₁	87	1	1.01-1.49	0.01	49		
5487-87-2	GB87B ₂	87	2	0.5-9.5	0.5	19		
				10-100	10	10		1945
5487-103-0	GB103B ₀	103	0	1.005	--	1	3.6	4790
5487-103-1	GB103B ₁	103	1	1.01-1.49	0.01	49		
5487-103-2	GB103B ₂	103	2	0.5-24.5	0.5	49		
				25-100	25	4		2245
5487-112-0	GB112B ₀	112	0	1.0005	--	1	3.7	5310
5487-112-1	GB112B ₁	112	1	1.001-1.009	0.001	9		
5487-112-2	GB112B ₂	112	2	1.01-1.49	0.01	49		
				0.5-24.5	0.5	49		3930
				25-100	25	4		2600

5489

钨钢块规

CARBIDE METRIC GAUGE BLOCKS



Unit:mm

Order No.	Model	Total blocks	Class	Nominal dimension(mm)	Steps (mm)	No. of blocks	N.W.	Price
5489-87-0	GB87C ₀	87	0	1.001-1.009	0.001	9	4.6	12505
5489-87-1	GB87C ₁	87	1	1.01-1.49	0.01	49		
5489-87-2	GB87C ₂	87	2	0.5-9.5	0.5	19		
				10-100	10	10		9115
5489-103-0	GB103C ₀	103	0	1.005	--	1	5.8	13630
5489-103-1	GB103C ₁	103	1	1.01-1.49	0.01	49		
5489-103-2	GB103C ₂	103	2	0.5-24.5	0.5	49		
				25-100	25	4		9800
5489-112-0	GB112C ₀	112	0	1.0005	--	1	6.1	14440
5489-112-1	GB112C ₁	112	1	1.001-1.009	0.001	9		
5489-112-2	GB112C ₂	112	2	1.01-1.49	0.01	49		
				0.5-24.5	0.5	49		11540
				25-100	25	4		10825

5491

高速钢针规

HIGH SPEED STEEL
PIN GAUGE



EACH .01mm GR 10E TSP 10E

Unit:mm

Order No.	Model	Nominal Dimension EACH 0.01mm FOR 1Pcs	Total Blocks	Weight(kg)	Price
5491-0510	GB0510E	0.50,051,0.52-1.00	51	1.11	3300
5491-1015	GB1015E	1.00,1.01,1.02-1.50	51	1.13	2970
5491-1520	GB1520E	1.50,1.51,1.52-2.00	51	1.15	2970
5491-2025	GB2025E	2.00,2.01,2.02-2.50	51	1.19	2970
5491-2530	GB2530E	2.50,2.51,2.25-3.00	51	1.23	2970
5491-3035	GB3035E	3.00,3.01,3.02-3.50	51	1.27	2970
5491-3540	GB3540E	3.50,3.51,3.52-4.00	51	1.33	2970
5491-4045	GB4045E	4.00,4.01,4.02-4.50	51	1.39	2970
5491-4550	GB4550E	4.50,4.51,4.52-5.00	51	1.47	2970
5491-5055	GB5055E	5.00,5.01,5.02-5.50	51	1.55	2970
5491-5560	GB5560E	5.50,5.51,5.52-6.00	51	1.63	2970
5491-6065	GB6065E	6.00,6.01,6.02-6.50	51	1.73	2970
5491-6570	GB6570E	6.50,6.51,6.52-7.00	51	1.83	2970
5491-7075	GB7075E	7.00,7.01,7.02-7.50	51	1.95	2970
5491-7580	GB7580E	7.50,7.51,7.52-8.00	51	2.07	2970
5491-8085	GB8085E	8.00,8.01,8.02-8.50	51	2.19	2970
5491-8590	GB8590E	8.50,8.51,8.52-9.00	51	2.33	2970
5491-9095	GB9095E	9.00,9.01,9.02-9.50	51	2.47	2970
5491-95100	GB95100E	9.50,9.51,9.52-10.00	51	2.63	2970

中空
卡盘
中空
油缸
后拉
夹盘
中实
卡盘
中实
油缸
气动
卡盘
超薄
夹头
手动
卡盘
轮毂
夹盘
卡盘
配件
生爪
硬爪
连接盘
拉料器
刀座
刀套
延长杆
顶尖
虎钳
分度盘
磨床
工具
磁盘
磁力
线割
表架
工具

车床
卡盘

铣床
虎钳

磨床
磁盘

线割
配件

机械
工具

- 中空卡盘
- 中空油缸
- 后拉夹盘
- 中实卡盘
- 中实油缸
- 气动卡盘
- 超薄夹头
- 手动卡盘
- 轮毂夹盘
- 卡盘配件
- 生爪硬爪
- 连接盘
- 拉料器
- 刀座
- 刀套
- 延长杆
- 顶尖
- 虎钳
- 分度盘
- 磨床工具
- 磁盘
- 万力
- 线割
- 表架
- 工具

5512 复合式粗目正弦磁台

COMPOUND SINE LATE WITH MAGNETIC CHUCK
CSPM

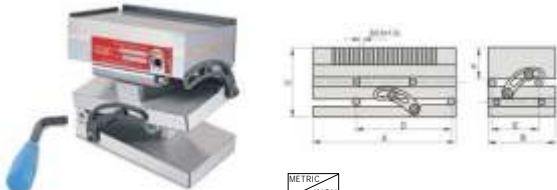

精度: ± 0.005

Order No.	Model	A	B	C	D	E	F	N.W.	Price							
5512-10	5512-15	CSP47M	175	7	100	4	122	5	100	75	3	47	1.85	14kg	5855	
5512-20	5512-25	CSP66M	150	6	150	6	122	5	100	5	100	5	47	1.85	18kg	6435
5512-22	5512-27	CSP510M	250	10	125	5	122	5	200	8	100	4	47	1.85	24kg	7605
5512-30	5512-35	CSP612M	300	12	150	6	122	5	200	10	100	5	47	1.85	35kg	9365

5515 筒式细目正弦磁台

SPS
ECONOMY SINE PLYATE WITH FINE MAGNETIC CHUCK



精度: ± 0.005

Order No.	Model	A	B	C	D	E	N.W.	Price						
5515-10	5515-15	SP47S	175	7	100	4	87	3.4	75	3	47	1.85	10.2kg	4975
5515-20	5515-25	SP66S	150	6	150	6	87	3.4	100	5	47	1.85	15kg	5270
5515-22	5515-27	SP510S	250	10	125	5	87	3.4	100	4	47	1.85	19kg	6435
5515-30	5515-35	SP612S	300	12	150	6	87	3.4	100	5	47	1.85	28kg	8780

5516 复合式细目正弦磁台

COMPOUND SINE PLATE WITH FINE MAGNETIC CHUCK
CSPS



精度: ± 0.005

Order No.	Model	A	B	C	D	E	F	N.W.	Price							
5516-10	5516-15	CSP47S	175	7	100	4	122	5	100	5	75	3	47	1.85	14kg	6435
5516-20	5516-25	CSP66S	150	6	150	6	122	5	100	5	100	5	47	1.85	18kg	7020
5516-22	5516-27	CSP510S	250	10	125	5	122	5	200	8	100	4	47	1.85	24kg	8190
5516-30	5516-35	CSP612S	300	12	150	6	122	5	200	10	100	5	47	1.85	35kg	10530

5520 一体超薄正弦磁台

SINE PLATE WITH FINE MAGNETIC CHUCK
MSP



精度: ± 0.005

Order No.	Model	A	B	C	D	E	F	N.W.	Price							
5520-35	5520-351	MSP35S	175	6.8	75	3	74	3	50	2	40	1.58	130	5	6.5kg	5560
5520-47	5520-471	MSP47S	225	9	102	4	87	3.4	75	3	47	1.85	175	7	11.5kg	6435
5520-66	5520-661	MSP66S	200	8	152	6	87	3.4	100	5	150	6	14.8kg	7020		
5520-510	5520-5101	MSP510S	300	12	127	5	87	3.4	100	4	175	5	250	10	20kg	7900
5520-412	5520-4121	MSP412S	350	14	102	4	87	3.4	100	3	175	5	300	12	19kg	9365
5520-612	5520-6121	MSP612S	350	14	152	6	87	3.4	100	5	175	5	300	12	28kg	10530

5522 复合式超薄正弦磁台

COMPOUND SINE PLATE WITH FINE MAGNETIC CHUCK
CMSP

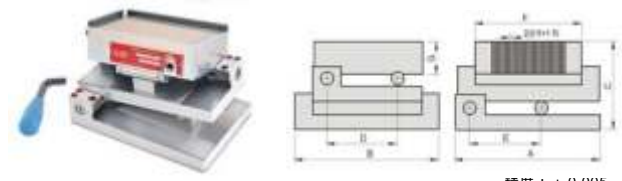

精度: ± 0.005

Order No.	Model	A	B	C	D	E	F	G	N.W.	Price								
5522-35	5522-351	CMSP35S	175	6.8	105	4	105	4	50	2	75	3	130	5	40	1.58	9.5kg	7020
5522-47	5522-471	CMSP47S	225	9	150	6	122	5	75	3	100	5	175	7	47	1.85	16.5kg	9365
5522-66	5522-661	CMSP66S	200	8	200	8	122	5	100	5	150	5	150	6	47	1.85	21.5kg	10530
5522-510	5522-5101	CMSP510S	300	12	175	7	122	5	100	4	200	10	250	10	47	1.85	28kg	11700

5535 微调式正弦磁台

FINE ADJUSTMENT SINE PLATE WITH MAGNETIC CHUCK



精度: ± 0.005

Order No.	Model	A	B	C	D	E	N.W.	Price
5535-35	MSP35SA	130	75	83	50	37	5.5kg	8190
5535-47	MSP47SA	175	100	92	75	41	11.5kg	9365
5535-66	MSP66SA	150	150	92	100	41	15kg	10530

5536 垂直形永磁吸盘

PERMANENT MAGNETIC CHUCK (VERTICAL TYPE)
MWS



精度: ± 0.002

Order No.	Model	Top plate			Bottom plate		Thickness		Height		Pole pitch P	N.W.	Price
		W	L	L1	L2	t3	t1	t2	H	H1			
5536-307	MW307S	75	175	130	180	65	67	20	111	30	1+1	10kg	7805
5536-407	MW407S	100	175	130	180	65	67	20	136	30	1+1	13kg	10075
5536-510	MW510S	125	250	205	255	65	67	20	161	30	1+1	23kg	13000

5537 超硬合金用永磁吸盘

PERMANENT MAGNETIC CHUCK
(FOR HARD ALLOY MATERIAL)
MTH

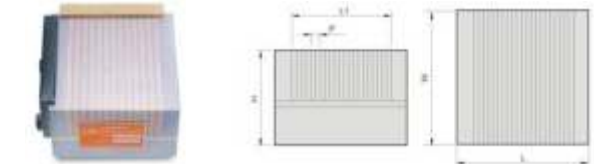

精度: ± 0.005

Order No.	Model	Nominal Dimension	Top plate			Pole pitch P	Height H	N.W.	Price
			W	L	L1				
5537-404	MT404H	105 × 80	105	105	69	6 (±1) + (±3)	60	5.2kg	10800
5537-407	MT407H	105 × 80	105	180	145	6 (±1) + (±3)	60	9.0kg	19210

5539

超薄形永磁吸盘 (不锈钢)

SUPER THIN TYPE PERMANENT MAGNETIC CHUCK
MTS

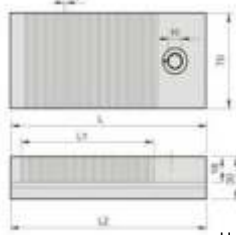

精度: ± 0.005

Unitmm

Order No.	Model	Nominal Dimension	Top plate L L1	Pole pitch P	Bottom plate L2	N. W.	Price
5539-305	MT305S	70 x 80	130 77	1.4(0.4+1)	130	2.2kg	5870
5539-307	MT307S	70 x 75	175 122	1.4(0.4+1)	175	2.9kg	6955

5548

细目永磁吸盘

MICROPITCH PERMANENT MAGNETIC CHUCK



精度: ± 0.005

Unitmm

Order No.	Model	Nominal Dimension	W	L	L1	P	t	H	N. W. (Kg)	Price
5548-02	407V	100 x 75	100	175	145	0.5+1.5	20	52	8kg	2045
5548-04	606V	150 x 50	150	150	115		20	52	8kg	2525
5548-06	510V	125 x 30	125	250	207		20	52	13kg	3190
5548-08	612V	150 x 30	150	300	257		23	60	21kg	4545
5548-10	614V	150 x 30	150	350	305		23	60	25kg	5345
5548-11	616V	150 x 40	150	400	357		23	60	28kg	6130
5548-12	618V	150 x 40	150	450	405		23	60	32kg	6870
5548-14	816V	200 x 40	200	400	357		23	60	37kg	8080
5548-16	818V	200 x 40	200	450	405		23	60	43kg	8980
5548-18	820V	200 x 50	200	500	457		23	60	53kg	10130

5540

粗目永磁夹盘 PERMANENT MAGNETIC CHUCK

AY

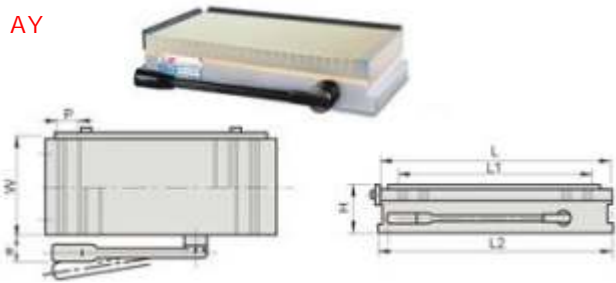

精度: ± 0.005

Unitmm

Order No.	Model	Nominal Dimension	W	L	L1	P	L2	e	H	N. W. (Kg)	Price
5540-02	1018AY	100 x 75	100	175	134	1.6+2 +1.6+6	187	42	52	7	2560
5540-04	1025AY	100 x 30	100	250	204		262	42		9	3555
5540-06	1030AY	100 x 30	100	300	260		312	42		11	4260
5540-08	1325AY	125 x 30	125	250	204		262	40		12	4420
5540-10	1530AY	150 x 30	150	300	260		312	32.5		16	6272
5540-12	1535AY	150 x 30	150	350	316		362	38.5		19	6930
5540-13	1540AY	150 x 40	150	400	356		412	38.5		22	7930
5540-14	1545AY	150 x 40	150	450	414		452	38.5		24	8915
5540-16	2035AY	200 x 30	200	350	302		362	36.5		25	9175
5540-18	2040AY	200 x 40	200	400	344		412	36.5		29	10160
5540-20	2045AY	200 x 40	200	450	400		462	36.5		32	11320
5540-22	2050AY	200 x 50	200	500	456		512	36.5		36	11960

5550

强力永磁细目夹盘

POWERFUL MICROPITCH PERMANENT MAGNETIC CHUCK

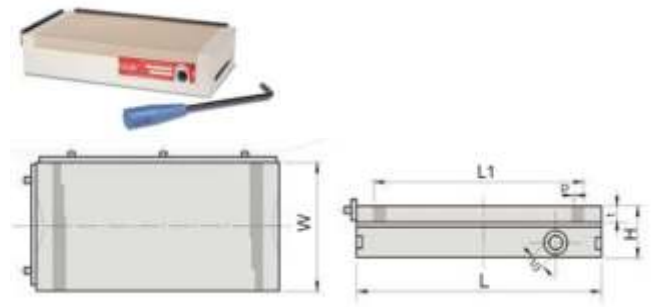

精度: ± 0.005

Unitmm

Order No.	Model	Nominal Dimension	W	L	L1	t	P	H	N. W. (Kg)	Price
5550-02	407W	100 x 75	100	175	125	18 (1+1)	2	52	7	3415
5550-04	606W	150 x 50	150	150	110				9	3985
5550-06	510W	125 x 30	125	250	205				12	4880
5550-08	612W	150 x 30	150	300	246				24	6235
5550-10	614W	150 x 30	150	350	296				24	7235
5550-12	618W	150 x 40	150	450	390				31	9210
5550-14	816W	200 x 40	200	400	349				37	11055
5550-16	818W	200 x 40	200	450	390				41.5	12190
5550-18	820W	200 x 50	200	500	446				46	13325

5545

强力永磁夹盘

POWERFUL ANGULAR PERMANENT MAGNETIC CHUCK

A

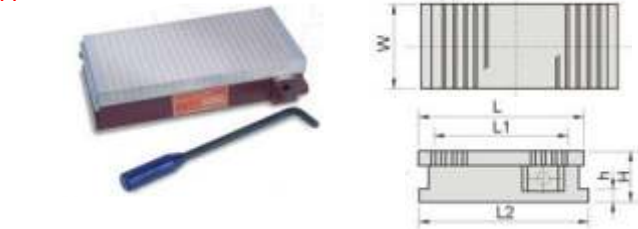

精度: ± 0.005

Unitmm

Order No.	Model	Nominal Dimension	W	L	L1	P	L2	e	H	N. W. (Kg)	Price
5545-02	407A	100 x 75	100	175	125	1.6+2 +1.6+6	187	13	52	7.3	2695
5545-04	510A	125 x 30	125	250	200		262			10.4	4665
5545-06	612A	150 x 30	150	300	246		312			15.1	6635
5545-08	614A	150 x 30	150	350	296		362			17.4	7340
5545-09	616A	150 x 40	150	400	346		412			18.9	8400
5545-10	618A	150 x 40	150	450	396		462			20.1	9440
5545-12	816A	200 x 40	200	400	346		412			26.0	10770
5545-14	818A	200 x 40	200	450	390		462			30.1	12000
5545-16	820A	200 x 50	200	500	446		512			35.7	12700
5545-18	1020A	250 x 50	200	500	446		512			45.6	15575

5553

圆形细目精密永磁吸盘

ROUND MICROPTICH PERMANENT MAGNETIC CHUCK

MCD

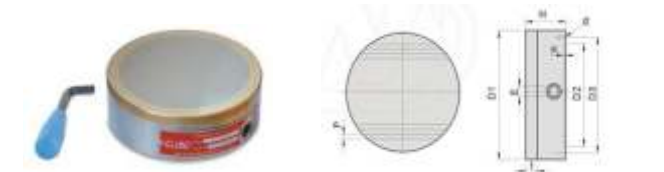

精度: ± 0.005

Unitmm

Order No.	Model	D1	D2	D3	K	d	P	H	t	E	N. W. (Kg)	Price
5553-080	MCD80	80	50	66	4	M6 M8 M10	0.5+1.5	50	10	8	1.8	2085
5553-100	MCD100	100	60	75	4						2.8	2795
5553-130	MCD130	130	90	115	4						5	3655
5553-150	MCD150	150	110	132	4						7	4930
5553-160	MCD160	160	120	140	4						8	5640
5553-200	MCD200	200	160	180	5						12.5	8140
5553-250	MCD250	250	200	225	5						19.5	11240
5553-300	MCD300	300	230	260	5						28.5	15555
5553-350	MCD350	350	230	260	5						39	23365
5553-405	MCD405	405	230	260	5			52	26690			

中空卡盘
中空油缸
后拉夹盘
中实卡盘
中实油缸
气动卡盘
超薄夹头
手动卡盘
轮毂夹盘
卡盘配件
生爪硬爪
连接盘
拉料器
刀座
刀套
延长杆
顶尖
虎钳
分度盘
磨床工具
磁盘
万力线割表架
工具

车床卡盘

铣床虎钳

磨床磁盘

线割配件

机械工具

中空卡盘
中空油缸
后拉夹盘
中实卡盘
中实油缸
气动卡盘
超薄夹头
手动卡盘
轮毂夹盘
卡盘配件
生爪硬爪
连接盘
拉料器
刀座
刀套
延长杆
顶尖
虎钳
分度盘
磨床工具
磁盘
万力
线割
表架
工具

5555 回转形永磁夹盘

ROTARY PERMANENT MAGNETIC CHUCK



精度: ± 0.005

Order No.	Model	Nominal Dimension	Chuck Dimension				Pole Pitch	Length Rotary Base						Height	N.W. (Kg)	Price	
			W	L	L1	H1		L2	w1	l1	l2	G	h1				h2
5555-07	407U	100 x 75	100	175	125	78	4(1+3)	283								17.5	6970
5555-10	510U	125 x 20	125	250	200			368	100	50	25	16	103	50	145	24.5	7565
5555-12	612U	150 x 30	150	300	246			418						27.2	9010		
5555-14	614U	150 x 30	150	350	296			468						30.4	11600		
5555-16	618U	150 x 40	150	450	396			568						35.4	15170		

5560 回转形微距形永磁夹盘

ROTARY MICROPITCH PERMANENT MAGNETIC CHUCK

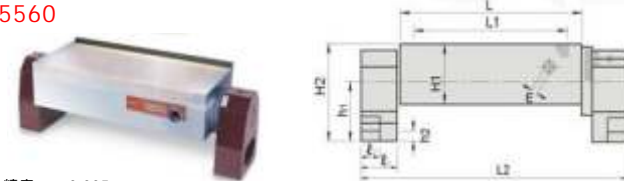

精度: ± 0.005

Order No.	Model	Nominal Dimension	Chuck Dimension				Pole Pitch	Length Rotary Base						Height	N.W. (Kg)	Price	
			W	L	L1	H1		L2	w1	l1	l2	G	h1				h2
5560-07	407UW	100 x 75	100	175	125	78	2(0.5+1.5)	283								17.5	9265
5560-10	510UW	125 x 20	125	250	200			368	100	50	25	16	103	50	145	24.5	11475
5560-12	612UW	150 x 30	150	300	246			418						27.2	13895		
5560-14	614UW	150 x 30	150	350	296			468						30.4	15300		
5560-16	618UW	150 x 40	150	450	396			568						35.4	18570		

5610 一寸不锈钢工具万力

TOOL MAKER VISE(STAINLESS STEEL)
VI10

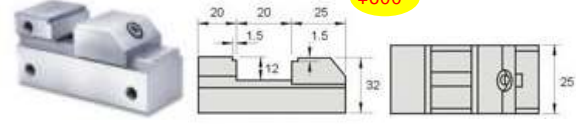

5625 不锈钢工具万力

TOOL MAKER VISE(STAINLESS STEEL)
VL20, 30



Order No.	Model	A	B	C	D	E	F	G	N.W. (Kg)	Price
5625-20	VL20	140	50	53	25	28	25	0-75m/m	1.8kg	3230
5625-30	VL30	180	72	62	30	32	35	0-100m/m	3.8kg	3830

5630 不锈钢手转工具万力

TOOL MAKER VISE(STAINLESS STEEL)
VSU30



Order No.	Model	A	B	C	D	E	F	G	N.W. (Kg)	Price
5665-60	AS60	90	60	50	25	0-35			1.6kg	3200
5665-70	AS70	160	70	62	30	0-80			4.3kg	4190
5665-90	AS90	210	90	80	40	0-120			8.4kg	9190

5655 VSB 里万力 VSB TOOL MAKER VISE VSB20-40

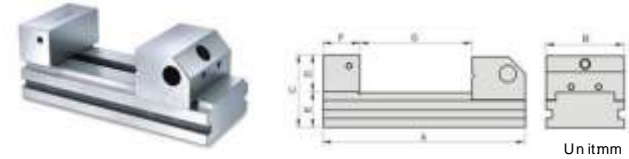

Order No.	Model	A	B	C	D	E	F	G	N.W. (Kg)	Price
5655-15	VSB15	105	36	48	20	28	20	0-45	1kg	780
5655-20	VSB20	150	48	53	25	28	25	0-75	2kg	960
5655-25	VSB25	176	63	59	30	29	30	0-95	3.3kg	1140
5655-30	VSB30	190	73	68	35	33	35	0-105	4.3kg	1495
5655-40	VSB40	245	98	90	45	45	45	0-135	10kg	2335

5660 高级万力 SUPER PRECISION TOOL MAKER VISE

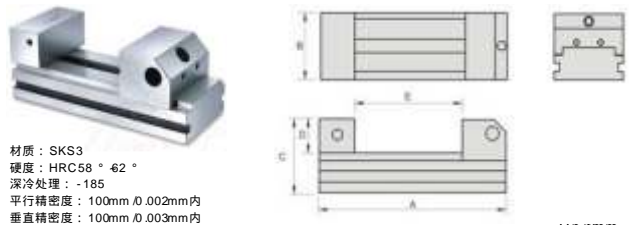

材质: SKS3
硬度: HRC58 ° ± 2 °
深冷处理: -185
平行精密: 100mm / 0.002mm内
垂直精密: 100mm / 0.003mm内

Order No.	Model	A	B	C	D	E	N.W. (Kg)	Price
5660-34	SV34	75	34	35	15	0-25	0.38kg	1975
5660-45	SV45	110	45	45	20	0-50	1.0kg	2770
5660-70	SV70	160	70	62	30	0-80	3.3kg	3485
5660-90	SV90	210	90	80	40	0-120	6.7kg	5585
5660-92	SV120	286	120	90	40	0-150	16.8kg	11445

5662 高级万力 SUPER PRECISION TOOL MAKER VISE

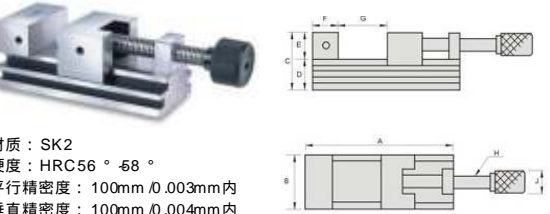

材质: SK2
硬度: HRC56 ° ± 5 °
平行精密: 100mm / 0.003mm内
垂直精密: 100mm / 0.004mm内

Order No.	Model	A	B	C	D	E	F	G	H	J	N.W. (Kg)	Price
5662-20	A20	140	48	55	30	25	25	0-75	M16	30	2.7kg	2655
5662-25	A25	160	63	69	39	30	30	0-85	M16	30	4.6kg	3095
5662-30	A30	180	73	78	43	35	35	0-95	M24	40	6.4kg	3760
5662-40	A40	230	98	92	47	45	45	0-120	M24	40	13kg	6650

5665 超精密工具万力 SUPER PRECISION TOOL MAKER VISE

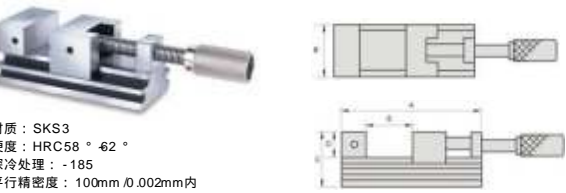

材质: SKS3
硬度: HRC58 ° ± 2 °
深冷处理: -185
平行精密: 100mm / 0.002mm内
垂直精密: 100mm / 0.003mm内

Order No.	Model	A	B	C	D	E	N.W. (Kg)	Price
5665-60	AS60	90	60	50	25	0-35	1.6kg	3200
5665-70	AS70	160	70	62	30	0-80	4.3kg	4190
5665-90	AS90	210	90	80	40	0-120	8.4kg	9190

5669

超精密工具万力

SUPER PRECISION TOOL MAKER VISE

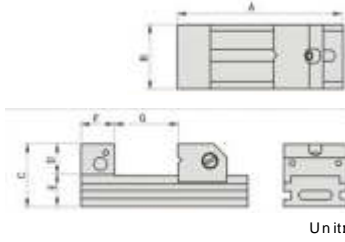

材质: SKS3
硬度: HRC58 ° ±2 °
深冷处理: -185
平行精密度: 100mm / 0.002mm内
垂直精密度: 100mm / 0.003mm内

Order No.	Model	A	B	C	D	E	F	G	N.W. (Kg)	Price
5669-30	VV30	190	73	70	35	35	38	0-100	4.6kg	7335
5669-40	VV40	230	98	80	40	40	46	0-125	11.4kg	11160
5669-50	VV50	300	125	98	50	50	60	0-160	18.5kg	21980
5669-60	VV60	350	150	100	50	50	60	0-210	24.9kg	26210

5680

精密级侧向正弦万力

PRECISION SINE VISE

L50

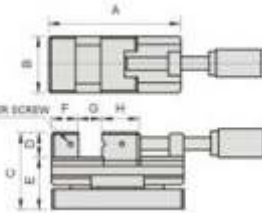

Model	A	B	C	D	E	F	G	H	I	Max.angle	N.W.(kg)	Price
L50	160	73	93	30	63	33	80	45	M5	46 °	6.5	6300

5735

手转正弦万力

TOOL MAKER SINE VISE

SV200、250、300、400

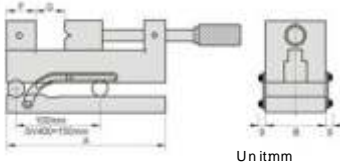

Order No.	Model	A	B	C	D	E	F	G	N.W. (Kg)	Price
5735-200	SV200	156	48	89	25	27	25	0-65	4.4kg	2155
5735-250	SV250	176	63	99	30	33	30	0-75	7kg	2455
5735-300	SV300	190	73	110	35	38	35	0-79	9kg	2750
5735-400	SV400	255	98	121	45	42	45	0-124	16kg	3890

5745

万向精密虎钳 PRECISION UNIVERSAL VISE

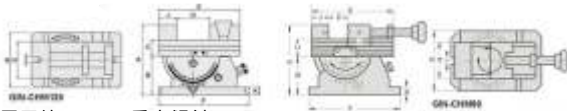

水平回转 360°, 垂直倾斜 45°

Order No.	Model	A	B	C	D	E	F	G	H	I	J	K	N.W. (Kg)	Price
5745-80	CHM80	137	75	32	80	160	180	110	70	12.5	32	15	14kg	5000
5745-120	CHM120	231	128	53	110	270	300	180	120	18	60	25	43kg	19635

5718

VB 工具万力 TOOL MAKER VISE

VB15-VB50

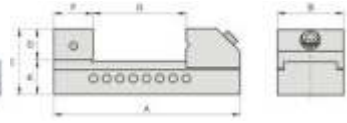

Order No.	Model	A	B	C	D	E	F	G	N.W. (Kg)	Price
5718-15	VB15	100	36	48	20	28	25	0-40	1kg	600
5718-20	VB20	150	50	53	25	28	30	0-80	1.8kg	750
5718-25	VB25	175	63	63	32	31	35	0-90	3.3kg	900
5718-30	VB30	190	73	70	35	35	35	0-100	4.3kg	1000
5718-35	VB35	235	88	80	40	40	40	0-130	7.5kg	1450
5718-40	VB40	245	100	90	45	45	45	0-130	10kg	1800
5718-50	VB50	285	125	100	50	50	45	0-160	15kg	2610

5710

一寸工具万力 TOOL MAKER VISE(SMALL)

VS10

精度: ± 0.003MM以内

N.W.0.3kg



¥455



5720

成型工具万力 TOOL MAKER VISE

VS

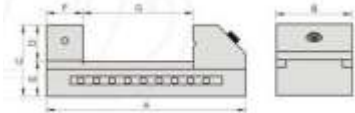

Order No.	Model	A	B	C	D	E	F	G	N.W. (Kg)	Price
5720-15	VS15	100	36	48	20	28	25	0-40	1kg	655
5720-20	VS20	150	50	53	25	28	30	0-80	1.8kg	800
5720-25	VS25	175	63	63	32	31	35	0-90	3.3kg	1000
5720-30	VS30	190	73	70	35	35	35	0-100	4.3kg	1100
5720-35	VS35	235	88	80	40	40	40	0-130	7.5kg	1545
5720-40	VS40	245	100	90	45	45	45	0-130	10kg	1900

5740

手转工具万力

TOOL MAKER VISE

VSD20、25、30、40

材质 SK2, 水平度在 0.003mm, 垂直度在 0.005mm.

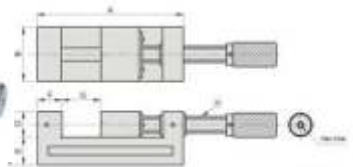

Order No.	Model	A	B	C	D	E	F	G	N.W. (Kg)	Price
5740-20	VSD20	156	48	52	25	27	25	0-65	2.5kg	1200
5740-25	VSD25	176	63	63	30	33	30	0-75	4.5kg	1400
5740-30	VSD30	190	73	73	35	38	35	0-79	6kg	1700
5740-40	VSD40	255	98	82	40	42	40	0-124	12kg	2600

中空
卡盘
中空
油缸
后拉
夹盘
中实
卡盘
中实
油缸
气动
卡盘
超薄
夹头
手动
卡盘
轮毂
夹盘
卡盘
配件
生爪
硬爪
连接盘
拉料器
刀座
刀套
延长杆
顶尖
虎钳
分度盘
磨床
工具
磁盘
万力
线割
表架
工具

车床
卡盘

铣床
虎钳

磨床
磁盘

线割
配件

机械
工具