

- 中空卡盘
- 中空油缸
- 后拉夹盘
- 中实卡盘
- 中实油缸
- 气动卡盘
- 超薄夹头
- 手动卡盘
- 轮毂夹盘
- 卡盘配件
- 生爪硬爪
- 连接盘
- 拉料器
- 刀座
- 刀套
- 延长杆
- 顶尖
- 虎钳
- 分度盘
- 磨床工具
- 磁盘
- 万力
- 线割
- 表架
- 工具

- 车床卡盘

- 铣床虎钳

- 磨床磁盘

- 线割配件

- 机械工具

5568 电控永磁吸盘

ELECTRICITY CONTROLS PERMANENT MAGNETIC CHUCK

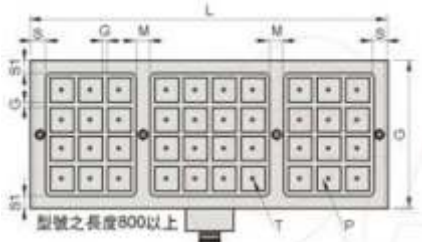
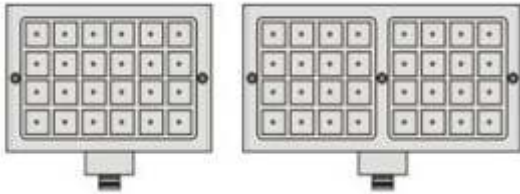

Unit mm Kg

Order No.	Model	尺寸						磁极数	磁极 P	电压	电流 A	磁极净重	控制器净重	Price
		W	L	S	S1	M	T							
5568-2540	EPM2540W	240	430			--		18	18	18	18	18	30000	
5568-2560	EPM2560W	240	590			30		24	24	24	24	24	36225	
5568-2580	EPM2580W	240	750			30		30	30	30	30	30	45900	
5568-2590	EPM2590W	240	870			30		36	36	36	36	36	50025	
5568-25100	EPM25100W	240	990			30		42	42	42	42	42	56100	
5568-3030	EPM3030W	300	310			--		16	16	16	16	16	27750	
5568-3040	EPM3040W	300	430			--		24	24	24	24	24	35250	
5568-3060	EPM3060W	300	590			30		32	32	32	32	32	44925	
5568-3080	EPM3080W	300	750			30		40	40	40	40	40	58200	
5568-3090	EPM3090W	300	870			30		48	48	48	48	48	62250	
5568-30100	EPM30100W	300	990			30		56	56	56	56	56	70950	
5568-4040	EPM4040W	420	430	30	25	--	M8	70	10	36	18	68	48000	
5568-4050	EPM4050W	420	480			--		42	42	42	42	42	54075	
5568-4060	EPM4060W	420	590			30		48	48	48	48	48	61725	
5568-4080	EPM4080W	420	750			30		60	60	60	60	60	80250	
5568-4090	EPM4090W	420	870			30		72	72	72	72	72	90000	
5568-40100	EPM40100W	420	990			30		84	84	84	84	84	102750	
5568-5060	EPM5060W	480	590			30		56	56	56	56	56	69375	
5568-5080	EPM5080W	480	750			30		70	70	70	70	70	94500	
5568-5090	EPM5090W	480	870			30		84	84	84	84	84	102000	
5568-50100	EPM50100W	480	990			30		98	98	98	98	98	116250	
5568-6060	EPM6060W	600	590			30		72	72	72	72	72	89250	
5568-6080	EPM6080W	600	750			30		90	90	90	90	90	116250	
5568-6090	EPM6090W	600	870			30		108	108	108	108	108	127500	
5568-60100	EPM60100W	600	990			30		126	126	126	126	126	150000	
5568-8080	EPM8080W	750	780			30		120	120	120	120	120	145500	

5750 可倾斜虎钳

UNIVERSAL 3-WAY ANGLE VISE

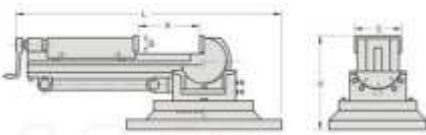

Unit mm

Order No.	Model	A	B	C	H	L	Vertical Height	N.W. (Kg)	Price
5750-03	VW3	90	30	80	150	396	386	17	4175
5750-04	VW4	105	38	106	172	460	470	33	4885
5750-05	VW5	140	40	132	205	625	590	45	6815

5760 角固式虎钳

PRECISION ANGLE LOCK MACHINE VISE

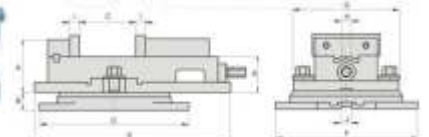

Unit mm

Order No.	Model	A	B	C	D	E	F	G	H	I	J	K	N.W. (Kg)	Price
5760-40	LV40	107	4	154	5 15/16	220	8 9/16	271	10 1/2	20			20	
5760-50	LV50	110	4 1/4	163	6 1/2	249	9 3/4	304	12	29			29	
5760-60	LV60	138	5 1/2	201	8	304	12	368	14 1/2	41			41	
5760-80	LV80	198	7 3/4	264	10 3/4	402	15 13/16	476	18 3/4	800			800	
5760-120	LV120	320	12 5/8	400	15 3/4	480	18 7/8	560	22	125			125	

Model	A	B	C	D	E	F	G	H	I	J	K	Price	
LV40	87 3/276/4	30 1 15/16	107	4	242 9 1/2	318 12 33/64	220 9 1/16	172 63/4	14 9/16	15 19/32	16 5/8	58 2 9/32	2890
LV50	98 3 55/64	32 1 1/4	110 4 1/4	280	11 35/16	355 14 25/64	256 10 11/16	210 81/4	15 19/32	15 19/32	16 5/8	66 2 19/32	3010
LV60	110 4 1/4	40 1 1/2	138 5 1/2	336 13 1/4	405 15 15/16	400 11 3/4	238 93/8	19 3/4	18 3/4	18 3/4	18 3/4	72 2 54/64	3795
LV80	136 5 27/64	55 2 3/16	198 7 3/4	422 16 5/8	555 21 3/4	380 15 305/12	19 3/4	24 15/16	19 3/4	24 15/16	18 3/4	84 3 5/16	5620
LV120	219 8 5/8	-	320 12 5/8	-	738 29 1/16	-	-	408 16 1/16	19 3/4	24 15/16	-	102 4	18545

5765 角固式光面直角虎钳

LOCK-TIGHT PRECISION MACHINE VISE

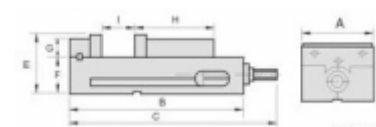

Unit mm

Order No.	Model	A	B	C	E	F	G	H	I	N.W. (Kg)	Price
5765-40	LG40	100	220	320	133	65	38	115	110	13kg	3105
5765-50	LG50	125	240	360	146	70	38	132	130	22kg	3280
5765-60	LG60	150	290	430	161	72	48	170	150	37kg	3450
5765-80	LG80	200	370	600	193	85	58	190	210	65kg	6730

5766 角固式虎钳

PRECISION ANGLE LOCK MACHINE VISE

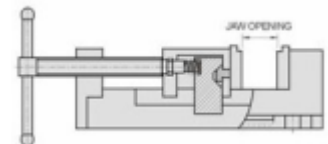

Unit mm

Order No.	Model	JAW PLATE HEIGHT	JAW PLATE HEIGHT	JAW OPENING	N.W. (Kg)	Price
5766-100	HDV-100	43	100	90	6.6kg	1615
5766-130	HDV-130	43	130	90	8.2kg	2280

5770 平面油压虎钳

HYDRAULIC MACHINE VISE

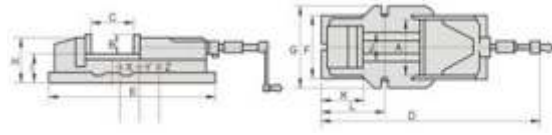

Unit mm

Order No.	Model	A	B	C	D	E	F	G	H	I	J	K	L	Clamping Force	N.W. (Kg) Body	N.W. (Kg) Swivel Base	Price
5770-100	HVA100	100	36	170	525	430	130	160	94	60	78	100	155	2500	16	6	4600
5770-125	HVA125	125	46	220	670	540	165	185	118	72	97	117	185	3500	33	7	5960
5770-150	HVA150	150	51	300	800	620	200	240	133	82	116	125	247	4500	54	16	5160
5770-200	HVA200	200	62	300	900	700	225	280	160	100	160	150	265	8500	90	20	9810

5775

双向油压虎钳 TILTING HYDRAULIC MACHINE VISE

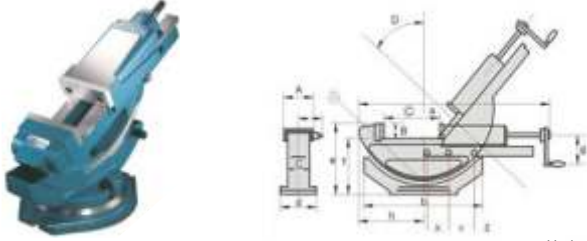

		Unit:mm														
Order No.	Model	A	B	C	D	a	b	c	d	e	f	g	h	N.W.(Kg) Body	N.W.(Kg) Swivel Base	Price
5775-100	HVW100	100	36	170	50	505	325	65	160	177	141	80	170	23	4	8565
5775-150	HVW150	150	51	300	50	775	410	95	240	237	186	100	200	60	10	10420

5780

倍力内藏式增压虎钳 MECHANICAL POWER MACHINE VISE

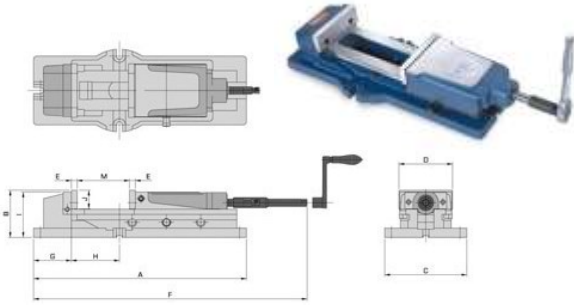

		Unit:mm														
Order No.	Model	A	B	C	D	E	F	G	H	I	J	M	N.W.(Kg)	Price		
5780-50	HMP50	538	118	185	130	15	670	105	82	117	46	220	38kg	8540		
5780-60	HMP60	620	133	240	154	17	800	110	140	132	54	300	58kg	9015		
5780-80	HMP80	700	162	280	206	21	900	135	118	160	62	300	105kg	16130		

5782

高级倍力外藏式增压虎钳 SUPER OPEN QUICK ACTION VISE



		Unit:mm															
Order No.	Model	A	B	C	D	E	F	G	H	I	J	K	L	M	N	N.W.(Kg)	Price
5782	HMP60A	200	18	300	77	610	139	158	82	63	200	240	190	915	18	58kg	10265

5785

向量式精密光面直角虎钳 PRECISION SUPER VISE

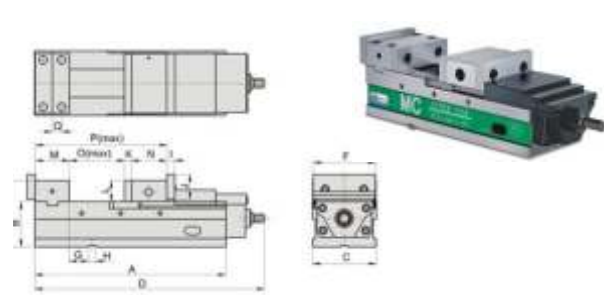

HVL100, 125, 160 s iohizonta & ertical ay vise.

		Unit:mm																		
Order No.	Model	A	B	C	D	E	F	G	H	I	J	K	L	M	N	O	P	Q	N.W.(Kg)	Price
5785-40	HVL100	324	85	104	437	130	102	32	18	17	55	15	45	73	86.5	140	314.5	20	27kg	7780
5785-50	HVL125	390	100	127	480	153	124.7	57	18	20	63	15	53	78	87.5	201	381.5	22.5	43kg	9965
5785-60	HVL160	485	115	161	625	168	159.2	49	18	20	63	18	53	86	80	295	479	25	71kg	12810

5786

倍力增压式精密光面直角虎钳 MECHANICAL POWER MACHINE VISE

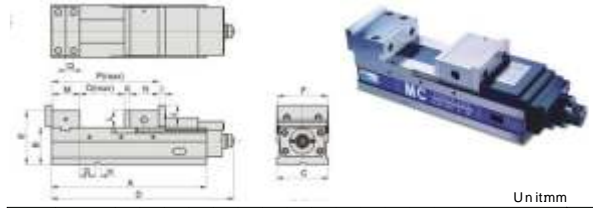

		Unit:mm																		
Order No.	Model	A	B	C	D	E	F	G	H	I	J	K	L	M	N	O	P	Q	N.W.(Kg)	Price
5786-40	HVC100	324	85	104	428	130	102	32	18	17	55	15	45	73	86.5	140	314.5	20	30kg	11385
5786-50	HVC125	390	100	127	495	153	124.7	57	18	20	63	15	53	78	87.5	201	381.5	22.5	46kg	12810
5786-60	HVC160	485	115	161	605	168	159.2	49	18	20	63	18	53	86	80	295	479	25	71kg	15940
5786-60L	HVC160L	515	115	161	635	168	159.2	67	18	20	63	18	53	86	80	330	514	25	76kg	20400
5786-80	HVC200	535	120	202	655	178	199.5	66	18	20	73	18	58	101	95	320	534	31	100kg	17080
5786-80L	HVC200L	585	120	202	713	178	200	84	18	20	73	18	58	101	95	367.5	581.5	31	108kg	20880

5788

多功能CNC角固式精密光面直角虎钳 MULTI-POWER CNC PRECISION FIXED ANGLE VISE

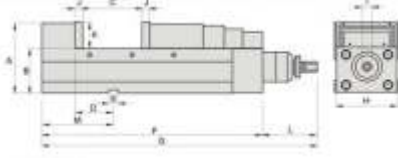

SPEC IFCATIONS Material:FC200 Ductile roth Hardness RC50 °

		Unit:mm																	
Order No.	Model	A	B	C	C1	C2	C3	D	E	F	G	H	I	J	K	L	M	N.W.(Kg)	Price
5788-130	HPAC130	147	85 ± 0.01	0-190	70-260	115-305	185-375	80 ± 0.02	18	475	583	131	19	15	55	120	150	47	13715
5788-160	HPAC160	160	105 ± 0.01	0-250	85-325	140-375	220-460	80 ± 0.02	18	560	670	161	19	15	58	120	165	65	16390
5788-200	HPAC200	170	110 ± 0.01	0-290	90-380	155-440	240-530	100 ± 0.04	18	635	743	201	19	18	63	120	197	95	21565

5792

双向向量式虎钳 Two-dimensional vector vise

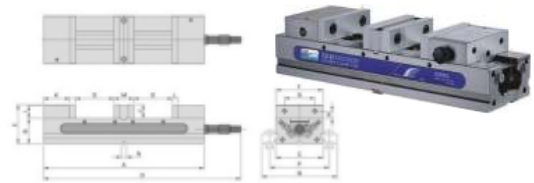

		Unit:mm																		
Order No.	Model	A	B	C	D	E	F	G	H	I	J	K	L	M	N	O	P	Q	N.W.(Kg)	Price
5792-40	TLD40	405	63.5	104	459	101.5	102	63.5	17.5	33	38	69	15	55	18	90	143	195	20kg	11385
5792-60	TLD60	520	82.55	154	536	127.05	152	98.4	23.8	41.5	44.5	86.5	15	66	18	125	193	245	52kg	13285

5796

MC增压器型超高压快速虎钳 MC PRECISION SUPER HI-PRESSURE RAPID VISCE



		Unit:mm																			
Order No.	Model	A	B	C	D	E	F	G	H	I	J	J1	J2	J3	K	L	M	X	精加 行程 (mm)	N.W. (Kg)	Price
5796-01	TPV5 80	520	380	140	130	157	160	86	15	110	0-150	95-250	110-275	200-300	55	105	18	45	6000	45	15830
5796-02	TPV6 80	540	400	140	160	160	163	86	15	120	0-160	95-260	120-295	210-400	55	105	18	45	6000	47	17680
5796-03	TPV6 80	630	490	140	160	160	163	86	15	120	0-250	95-350	120-395	210-490	55	105	18	45	6000	53	18720
5796-04	TPV7 80	600	460	140	180	170	173	90	18	130	0-200	100-300	130-350	220-460	63	110	18	72	9000	65	19750
5796-05	TPV8 20	610	470	140	200	170	173	90	18	140	0-200	100-310	140-360	230-470	63	110	18	72	9000	70	21735
5796-06	TPV8 80	710	570	140	200	170	173	90	18	140	0-300	100-410	140-460	230-570	63	110	18	72	9000	79	22900

中空
卡盘
中空
油缸
后拉
夹盘
中实
卡盘
中实
油缸
气动
卡盘
超薄
夹头
手动
卡盘
轮毂
夹盘
卡盘
配件
生爪
硬爪
连接盘
拉料器
刀座
刀套
延长杆
顶尖
虎钳
分度盘
磨床
工具
磁盘
磁力
线割
表架
工具

车床
卡盘

铣床
虎钳

磨床
磁盘

线割
配件

机械
工具

中空卡盘
中空油缸
后拉夹盘
中实卡盘
中实油缸
气动卡盘
超薄夹头
手动卡盘
轮毂夹盘
卡盘配件
生爪硬爪
连接盘拉料器
刀座刀套
延长杆
顶尖
虎钳
分度盘
磨床工具
磁盘
万力
线割表架
工具

车床卡盘

铣床虎钳

磨床磁盘

线割配件

机械工具

5810-5812

万能分度头
SEMI-UNIVERSAL CENTER (DIVIDING HEAD)



SEMI-UNIVERSAL CENTER B & P/B (NO. 1) (HEAD-STOCK) Unit:mm

Order No.	Model	A	B	C	D	E	F	G	N.W. (Kg)	Price							
5810	BS0	189	77/16	160	6 19/64	100	315/16	173	613/16	16	5/8	91	337/64	140	5 33/64	22	7420
5812	BS1	293	111/32	210	8 17/64	128	53/64	220	53/64	16	5/8	114	431/64	156	6 9/64	36	9750

SEMI-UNIVERSAL CENTER B & P/B (NO. 1) (TAIL-STOCK) Unit:mm

Model	a	b	c	d	e	f	Taper of Center	Diameter of Spindle hole						
BS0	90	335/64	105	49/64	16	5/8	100	315/16	166	634/64	127	5	B&S No.7	18
BS1	108	41/4	134	59/32	16	5/8	128	529/32	184	71/4	150	529/32	B&S No.9	20

STANDARD ACCESSORIES
Dividing plate A, B, C.
Numbers of holes of dividing plate(worm gear reduction ratio 1:40) Unit:mm

Numbers of holes	PlateA	15	16	17	18	19	20
	PlateB	21	23	27	29	31	33
	PlateC	37	39	41	43	47	49

5820

横立两用分度盘
HORIZONTAL AND VERTICAL ROTARY TABLE

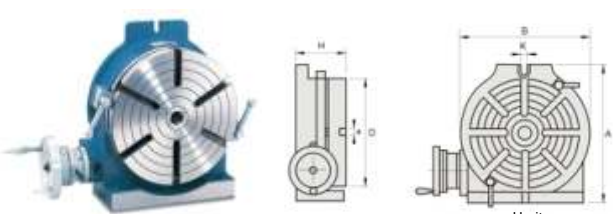

Unit:mm

Order No.	Model	Table		Base Dimension		Bolt Slots K	Center sleeve	Worm Gear Ratio	N.W. (Kg)	Price
		D	H	A	B					
5820-15	HV150	150	92	220	160	18	MT-2	90:1	12.5	3880
5820-20	HV200	200	120	310	225	18	MT-3		31.0	5450
5820-25	HV250	250	120	320	280	18	MT-3		48.5	6790
5820-30	HV300	300	140	410	325	18	MT-4		77.0	8660
5820-35	HV350	350	140	460	380	18	MT-4		98	11095
5820-40	HV400	400	140	510	435	18	MT-5		130	16045

5821

尾座
TAIL STOCK

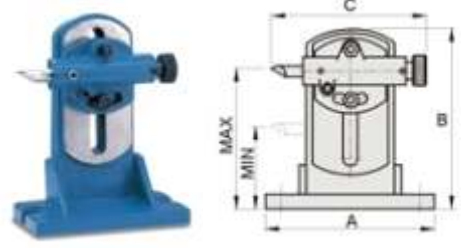

Unit:mm

Order No.	Model	Suitable for	A	B	C	Center Height		n.w. (Kg)	Price
						Max.	Min.		
5821-01	TS1	HV-200/HV-250	230	247	210	190	110	13	1440
5821-02	TS2	HV-300	230	280	210	220	140	15	1520
5821-03	TS3	HV-350/HV-400	230	330	210	264	184	17	1900

5865

万能可调倾斜式角度盘
ANGLE PLATE+CONNECTING PLATE+SWIVELBASE

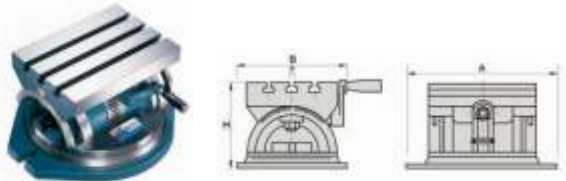

Unit:mm

Order No.	Model	A	B	H	T-SLOT e	N.W. (Kg)	Price
5865-02	HAP250S	350	305	185	12	40	8025
5865-03	HAP380S	490	436	240	16	100	12075

5855

万能倾斜分度盘
UNIVERSAL TILTING ROTARY TABLE

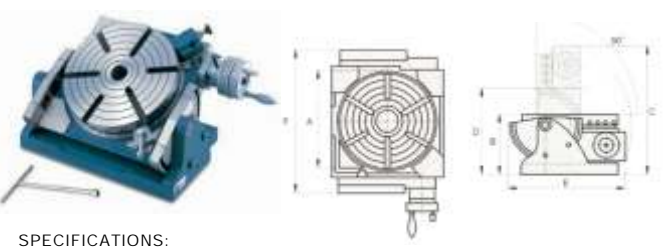

SPECIFICATIONS: Unit:mm

Order No.	Model	Table Diameter A	Table Height Horizontal(B)	Table Height Vertical(C)	Center Height Vertical(D)	E	F	Gear Ratio	Center Hole	Direct Indexing	N.W. (Kg)
5855	HUT300	300mm	185mm	405mm	228mm	336	444	90:1	MT5	24-div	93

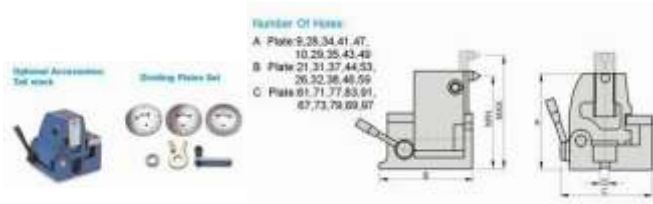

Unit:mm

Order No.	Model	A	B	C	D	Center Height		N.W. (Kg)	Price
						Max	Min		
5855	HUT300	200	196	190	16	230	113	23	27420

- 中空卡盘
- 中空油缸
- 后拉夹盘
- 中实卡盘
- 中实油缸
- 气动卡盘
- 超薄夹头
- 手动卡盘
- 轮毂夹盘
- 卡盘配件
- 生爪
- 硬爪
- 连接盘
- 拉料器
- 刀座
- 刀套
- 延长杆
- 顶尖
- 虎钳
- 分度盘
- 磨床
- 工具
- 磁盘
- 万力
- 线割
- 表架
- 工具

车床卡盘

铣床虎钳

磨床磁盘

线割配件

机械工具